

**"FROM START TO FINISH,
ACCEPT NO SUBSTITUTES!"**



METAL | 2022 PUBLICATION



ABOUT TIMESAVERS

Timesavers manufactures some of the most powerful and efficient metalworking solutions in the industry. Our metal grinders and deburring machines are fully customizable and can be equipped with a wide variety of different head types to automate almost any metalworking project. We understand that different projects and executions require different technology, and that's why we also offer the industry's largest range of machine configurations and features (including head configurations, wet-vs-dry, abrasive selection, etc.) to ensure that our metal grinders meet and exceed your expectations and demands. Make no mistake, nobody offers a wider selection of versatile and high-quality automated grinding solutions than Timesavers.

TIMESAVERS | PRODUCT SUMMARY



METAL

CREATIVITY AND TECHNOLOGY GO HAND-IN-HAND AT TIMESAVERS

We subscribe to the premise that different options are required for different applications and there is nobody who offers a broader range of machines than Timesavers. In addition, Timesavers also develops and produces machines for special applications up to complete turnkey project solutions with innumerable types of peripheral equipment. Timesavers thinks in terms of solutions and likes to meet your challenge with vigour and enthusiasm.

HEAD TYPES:

- + Wet
- + Dry
- + Wide Belt
- + Brush
- + Hammerhead/Slag Grinder

MACHINE LINES:

- + 11 Series
- + 12 Series
- + 22 Series
- + 32 Series
- + 42 Series
- + Rotary Brush
- + 31 Series (Lynx)
- + 41 Series (Puma)
- + Manual Grinder
- + Hammerhead/Slag Grinder
- + Dust Collection



WOOD

TIMESAVERS IS THE LEADER IN WOOD SANDING MACHINERY

Timesavers has over 70 years of experience in manufacturing woodworking machinery. Our wood sanders are built with the automation of professional craftsmanship in mind, utilizing the best and most durable components to guarantee peerless performance and reliability. We understand full well that each woodworking project has unique requirements and specifications, and that's why we offer an extensive variety of head types and machine lines to match your needs. Timesavers will stop at nothing to ensure that you find the perfect machine for your application, saving you valuable time and increasing your bottom line in the process.

HEAD TYPES:

- + Knife Planer
- + Wide Belt
- + Segmented Polisher
- + Orbital
- + Brush Machines
- + CNC Sander
- + Top/Bottom

MACHINE LINES:

- + SpeedSander
- + 13 Series
- + 23 Series
- + 33 Series
- + 53 Series
- + Yieldsaver
- + Moulding Sander

TIMESAVERS®
.....
SERIES



NIAGARA-5
.....
SERIES



NIAGARA-10
.....
SERIES



NIAGARA-15
.....
SERIES



NIAGARA-25
.....
SERIES

TIMESAVERS: THE BEST WHEN IT COMES TO METAL MACHINING EQUIPMENT

Timesavers offers solutions for deburring, edge rounding, finishing and precision grinding of Zintec, aluminum, copper, mild steel, stainless steel, titanium and alloy parts

DEBURRING WITH A TIMESAVERS DEBURRING MACHINE

Deburring is the removal of irregularities on metals. They can mainly be found on the edges of the material and are often caused by machining work such as laser, water jet, punched or plasma cutting. Discover Timesavers' broad machine line for effective and efficient deburring.

GET THE BEST FINISH WITH TIMESAVERS

Machine finishing applies to, for example, stainless steel and aluminum in two versions: a hairline and a grain finish. Timesavers offers a wide range of quality finishes with abrasive belts and brushes.

ARE YOU LOOKING FOR THE MOST BEAUTIFUL AND BEST ROUNDING OF METAL?

A radius is created on the edge of the metal during edge rounding of metal products. This ensures that the sharpness of the edge is removed and it is given a uniform rounding. Timesavers offers perfection in edge rounding with a radius of up to two mm in a single pass.

PRECISION GRINDING WITH TIMESAVERS' INNOVATIVE GRINDING TECHNOLOGY

Surplus material such as the oxide layer is removed from metal products through surface grinding when you apply precision grinding.

SLAG REMOVAL

Slags occur when metal melts because of, for example, autogenous and plasma cutting. Slag removal deserves a special approach for which Timesavers offers the ultimate solutions.

REMOVAL OF LASER OXIDE SKIN WITH TIMESAVERS' RECENT INNOVATION

Laser oxide occurs on metal and stainless steel when laser cutting using oxygen, and it must be removed for subsequent coating processes. Timesavers has developed a perfect solution for the removal of laser oxide.



NIAGARA Wet Dust Collectors

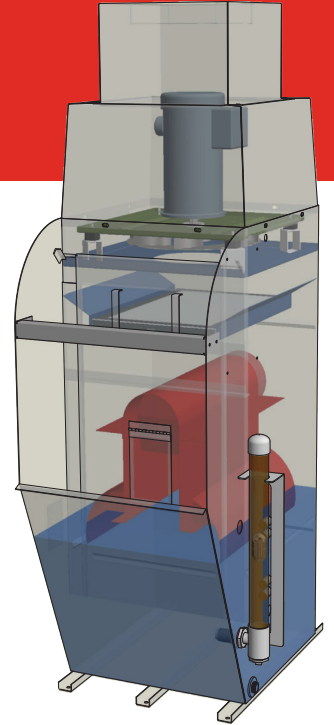
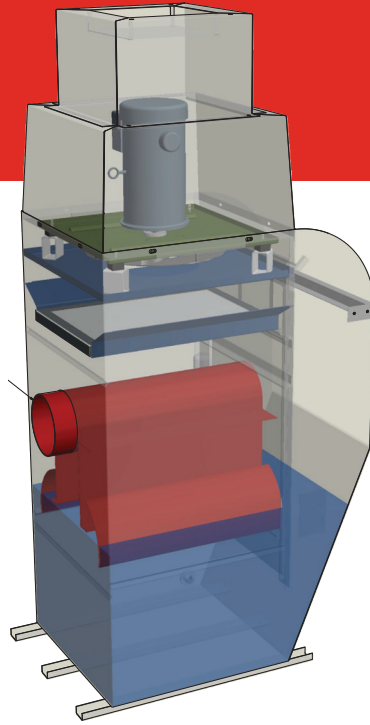

Overview:

- 100% stainless steel construction with 5 year limited warranty on tank
- TEFC rated motors
- Stainless steel impeller designed with backward curve blades balanced at 3,600 rpm
- Secondary filter (mist eliminator)
- Easy to remove access door with explosion relief gate
- Silencer to ensure noise levels below 84 decibels
- Electronic high/low water level sensors
- Automatic filling system
- Water level gauge
- Brass fittings and stainless steel hardware to prevent rust
- Inlet connection with steel flange and reducer
- One (1) inch drain with gate valve for ease of cleaning
- Special clean-out rake
- External surfaces painted with industrial two-component paint
- Main power disconnect

Options:

- Standard spiral pipe kit
- Quick clamp pipe kit
- Sound dampening kit



NIAGARA-5 Wet Dust Collector



The Timesavers model Niagara-5 is intended for safe, efficient collection of various dusts from grinding and deburring operations. Using a water-filled tank as the filter into which the contaminated air is pulled, dust particles sink to the base of the tank and are easily raked into a disposal container. Superior design and construction of the Timesavers Model Niagara-5 Wet Dust Collector gives you the competitor edge.

STANDARD FEATURES

- 100% Stainless Steel Construction • Main Motor • Main Tank • Baffles • Access Door • Silencer • Water Float Level • Water Drain Valve Water Level Scale • Impeller • Electrical Equipment • Mist Eliminator • **US Manufactured**

Dimensions	42" x 34"	Voltage/Phase/Frequency	230/460V- 60Hz	Approximate shipping weight	800 lbs.
Air CFM	2,400	Approximate full load amps at 230 volt	16		
Inlet size	7"	Motor	5 HP, TEFC		



NIAGARA-10 Wet Dust Collector



The Timesavers model Niagara-10 is intended for safe, efficient collection of various dusts from grinding and deburring operations. Using a water-filled tank as the filter into which the contaminated air is pulled, dust particles sink to the base of the tank and are easily raked into a disposal container. Superior design and construction of the Timesavers Model Niagara-10 Wet Dust Collector gives you the competitor edge.

STANDARD FEATURES

Main Motor • Main Tank • Baffles • Access Door • Silencer • Water Float Level • Water Drain Valve
• Water Level Scale • Impeller • Electrical Equipment • Eliminator Grid • **US Manufactured**

Dimensions	51" x 51.5"	Voltage/Phase/Frequency	230/460V- 60Hz	Approximate shipping weight	1,600 lbs.
Air CFM	3,000	Approximate full load amps at 230 volt	22		
Inlet size	8"	Motor	10 HP, TEFC		



NIAGARA-15 Wet Dust Collector



The Timesavers model Niagara-15 is intended for safe, efficient collection of various dusts from grinding and deburring operations. Using a water-filled tank as the filter into which the contaminated air is pulled, dust particles sink to the base of the tank and are easily raked into a disposal container. Superior design and construction of the Timesavers Model Niagara-15 Wet Dust Collector gives you the competitor edge.

STANDARD FEATURES

- 100% Stainless Steel Construction • Main Motor • Main Tank • Baffles • Access Door • Silencer • Water Float Level • Water Drain Valve Water Level Scale • Impeller • Electrical Equipment • Mist Eliminator • **US Manufactured**

Dimensions	51" x 51.5"	Voltage/Phase/Frequency	230/460V- 60Hz	Approximate shipping weight	1650 lbs.
Air CFM	4,000	Approximate full load amps at 230 volt	37		
Inlet size	10"	Motor	15 HP, TEFC		



NIAGARA-25 Wet Dust Collector



The Timesavers model Niagara-25 is intended for safe, efficient collection of various dusts from grinding and deburring operations. Using a water-filled tank as the filter into which the contaminated air is pulled, dust particles sink to the base of the tank and are easily raked into a disposal container. Superior design and construction of the Timesavers Model Niagara-25 Wet Dust Collector gives you the competitor edge.

STANDARD FEATURES

- 100% Stainless Steel Construction • Main Motor • Main Tank • Baffles • Access Door • Silencer • Water Float Level • Water Drain Valve Water Level Scale • Impeller • Electrical Equipment • Mist Eliminator • **US Manufactured**

Dimensions	71.5" x 73.5"	Voltage/Phase/Frequency	230/460V- 60Hz	Approximate shipping weight	2,450 lbs.
Air CFM	7,000	Approximate full load amps at 230 volt	60		
Inlet size	12"	Motor	25 HP, TEFC		





FROM START TO FINISH

SAVERS®

TIME SAVERS

TIME SAVERS
SERIES 1200

120V



METAL



TIMESAVERS, LLC

11123 89th Ave North
Maple Grove, Minnesota USA
T +763 488 6600
info@timesaversinc.com
www.timesaversinc.com

